

### FEATURES

- Single Video Line Driver Chip
- Internal Clamp and Feedback Resistors
- $R_L=150\ \Omega$  (75  $\Omega$  Back-Terminated Cable)
- Power-Down Standby Mode
- Tiny 2.9 x 1.6 mm 6-Lead SOT23 Package
- Low Power Dissipation: 37.5 mW
- 1 V<sub>P-P</sub> Input Range, 6 dB Voltage Gain
- Flat Response  $f_{IN} = 100\ \text{kHz}$  to 10 MHz (typical)
- Single +5 Volt Power Supply

### APPLICATIONS

- Digital Video Disk
- Video Line Driver for Encoders
- Digital Video Tape Recorders
- Video Cassette Recorders
- PC Multimedia
- Consumer Video

### GENERAL DESCRIPTION

The SPT9405 is a single video line driver chip that takes a standard video signal as an analog input and provides a buffered analog output for driving a 150  $\Omega$  load (75  $\Omega$  back-terminated cable). The standard video input signal (1 V<sub>P-P</sub>) is internally clamped and amplified 6 dB using internal circuitry and feedback resistors to produce a 2 V<sub>P-P</sub> into an AC-coupled 150  $\Omega$  load. The internal 1.5 k $\Omega$  resistor provides gain

compensation for low frequency signals. (See the typical interface circuit diagram.)

The SPT9405 features a standby mode which draws only 120  $\mu\text{W}$  of power. Nominal power dissipation (no input) is typically 37.5 mW. It requires a single +5 V supply, operates over the commercial temperature range (0 to +70  $^{\circ}\text{C}$ ) and is available in a tiny surface mount (2.9 x 1.6 mm) 6-lead SOT-23 package.

### BLOCK DIAGRAM

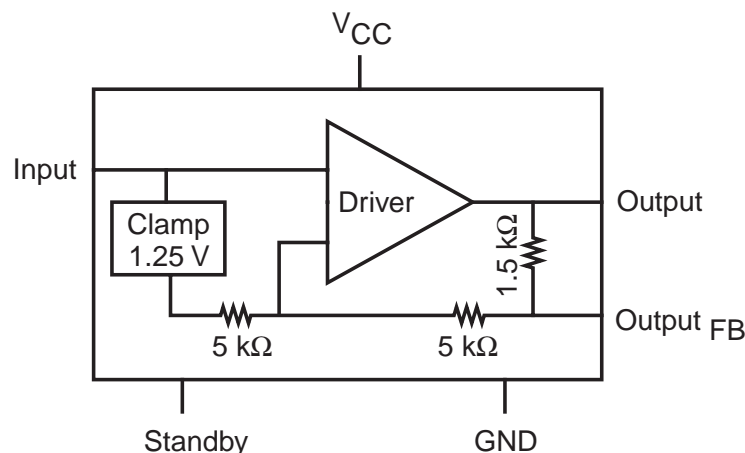

**Signal Processing Technologies, Inc.**

4755 Forge Road, Colorado Springs, Colorado 80907, USA

Phone: (719) 528-2300 FAX: (719) 528-2370

## ABSOLUTE MAXIMUM RATINGS (Beyond which damage may occur)<sup>(1)</sup> 25 °C

### Supply Voltages

V<sub>CC</sub> ..... +6.0 V

### Maximum Power Dissipation

P<sub>D</sub> ..... 150 mW

### Thermal Impedance (T<sub>A</sub>=+25 °C and above)

θ<sub>CA</sub> ..... 1.2 mW/°C

### Temperature

Operating Temperature ..... 0 to +70 °C

Storage Temperature ..... -55 to +150 °C

**Note:** 1. Operation at any Absolute Maximum Rating is not implied. See Electrical Specifications for proper nominal applied conditions in typical applications.

## ELECTRICAL SPECIFICATIONS

T<sub>A</sub> = +25 °C, V<sub>CC</sub> = +5.0 V, V<sub>IN</sub> = 1.0 V<sub>P-P</sub> video signal, R<sub>L</sub> = 150 Ω, unless otherwise specified.

PARAMETERS	TEST CONDITIONS	TEST LEVEL	SPT9405			UNITS
			MIN	TYP	MAX	
Power Supply						
Supply Current (I <sub>CC</sub> )	No Input	I		7.5	10	mA
V <sub>CC</sub> Voltage		IV	4.5	5.0	5.5	V
Power Dissipation		I		37.5	50	mW
Standby Current	Pin 1 Grounded	I		24.0	50	μA
Standby Power Dissipation	Pin 1 Grounded	I		120	250	μW
Digital Input						
Digital Input (Low)	Standby Pin 1	I	0.0	0.1	0.3	V
Digital Input (High)	Standby Pin 1	I	1.8	2.0	V <sub>CC</sub>	V
Bias Voltage						
Clamp Voltage	Pin 4	I	1.05	1.25	1.45	V
Dynamic Performance						
Voltage Gain	f <sub>IN</sub> = 1 MHz	I	5.4	5.9	6.4	dB
Differential Gain	Ramp Input 3.58 MHz	I	-3.0	-0.6	+3.0	%
Differential Phase	Ramp Input 3.58 MHz	I	-3.0	-0.2	+3.0	Degrees
Frequency Response	f <sub>IN</sub> = 1 to 5 MHz	V		-0.5		dB

### TEST LEVEL CODES

All electrical characteristics are subject to the following conditions:

All parameters having min/max specifications are guaranteed. The Test Level column indicates the specific device testing actually performed during production and Quality Assurance inspection. Any blank section in the data column indicates that the specification is not tested at the specified condition.

### TEST LEVEL

I  
II  
III  
IV  
V  
VI

### TEST PROCEDURE

100% production tested at the specified temperature.  
100% production tested at T<sub>A</sub> = +25 °C, and sample tested at the specified temperatures.  
QA sample tested only at the specified temperatures.  
Parameter is guaranteed (but not tested) by design and characterization data.  
Parameter is a typical value for information purposes only.  
100% production tested at T<sub>A</sub> = +25 °C. Parameter is guaranteed over specified temperature range.

Figure 1 - Typical Interface Circuit

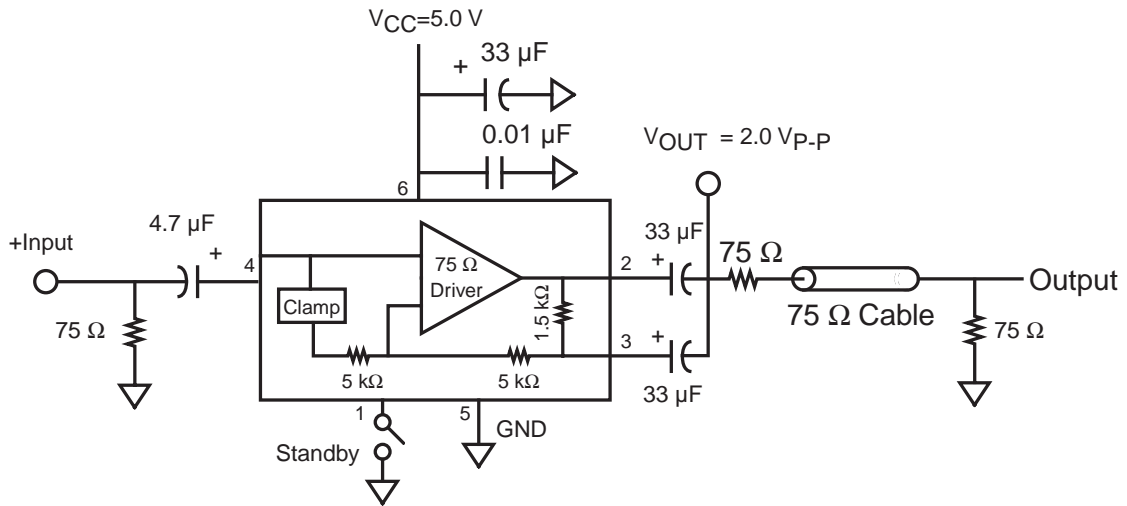

## PACKAGE OUTLINE

6-Lead SOT23

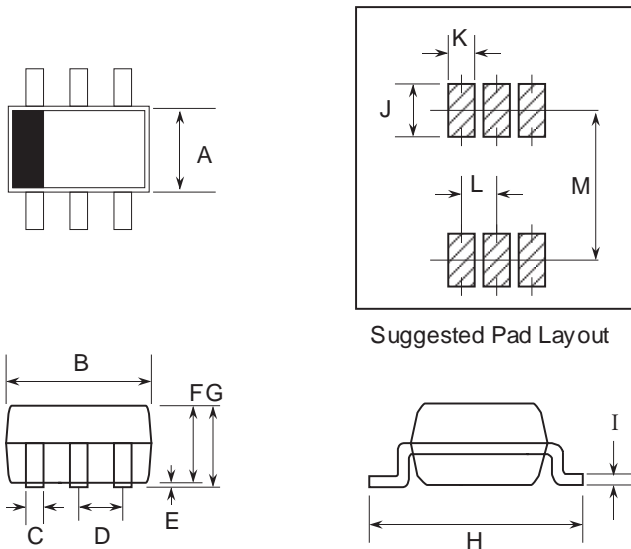

SYMBOL	INCHES		MILLIMETERS	
	MIN	MAX	MIN	MAX
A	0.055	0.071	1.4	1.8
B	0.106	0.122	2.7	3.1
C	0.008	0.016	0.2	0.4
D	0.037 typ		0.95 typ	
E	0.000	0.004	0.0	0.1
F	0.035	0.051	0.9	1.3
G		0.071 max		1.4 max
H	0.098	0.122	2.5	3.1
I	0.001	0.009	0.03	0.23
J	0.039 typ		1.0 typ	
K	0.028 typ		0.7 typ	
L	0.037 typ		0.95 typ	
M	0.094 typ		2.4 typ	

## PIN ASSIGNMENTS

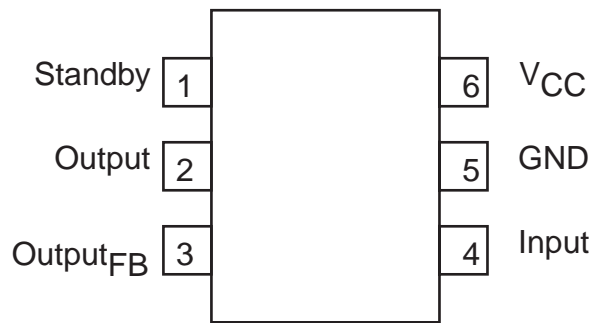

## PIN FUNCTIONS

Name	Function
Input	Video Signal Input (typically 1 V <sub>P-P</sub> , AC coupled)
Output	Buffered Output (typically 2.0 V <sub>P-P</sub> , R <sub>L</sub> = 150 Ω, AC coupled)
Output <sub>FB</sub>	Output Feedback Pin
Standby	Power Down Standby Mode Select (Low = Standby, Internal Pull-Up)
V <sub>CC</sub>	+5.0 V Supply
GND	Ground

## ORDERING INFORMATION

PART NUMBER	TEMPERATURE RANGE	PACKAGE TYPE
SPT9405SCL	0 to +70 °C	6-Lead SOT23

Signal Processing Technologies, Inc. reserves the right to change products and specifications without notice. Permission is hereby expressly granted to copy this literature for informational purposes only. Copying this material for any other use is strictly prohibited.

**WARNING - LIFE SUPPORT APPLICATIONS POLICY** - SPT products should not be used within Life Support Systems without the specific written consent of SPT. A Life Support System is a product or system intended to support or sustain life which, if it fails, can be reasonably expected to result in significant personal injury or death.

Signal Processing Technologies believes that ultrasonic cleaning of its products may damage the wire bonding, leading to device failure. It is therefore not recommended, and exposure of a device to such a process will void the product warranty.